

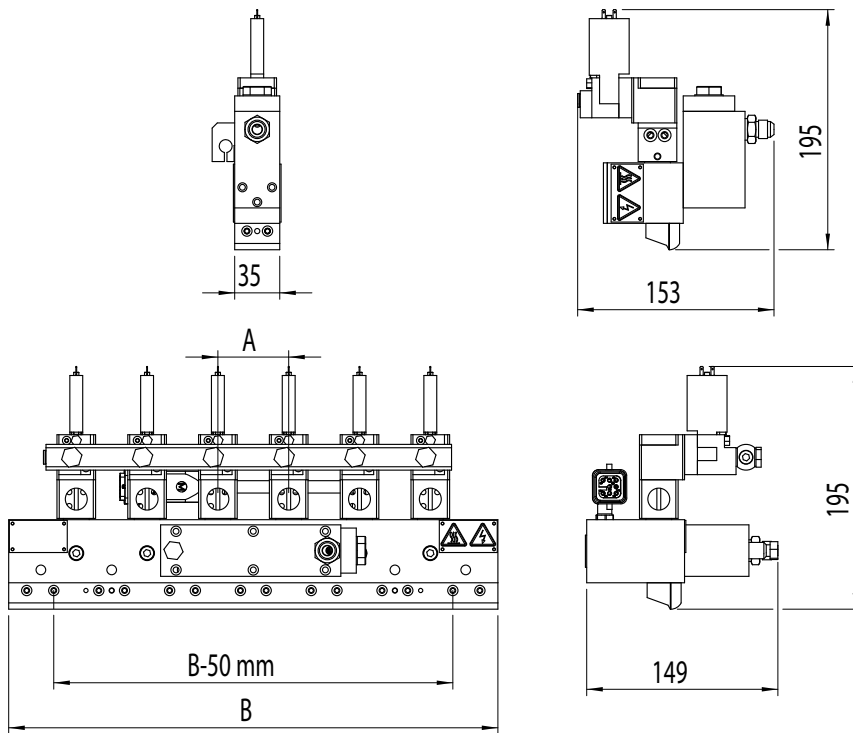

# slot applicator HMC45NV

intermittent coating head for high speed applications



APRO slot applicator series HMC45NV have been developed for fast intermittent coating applications. We use the well known snuffback valve technology, where the valve operates in the opposite direction to the adhesive flow. This guarantees an optimized, very sharp and precise cutoff. All of our applicators are available as return flow systems if needed. APRO has specific know-how for years to identify and realize your needs.

#### Our standard features:

- glue filter as standard
- reliable control module easy to be repaired
- high quality heater cartridges and temperature sensors
- ready-to go available for major brands adhesive supply units (with correct sensor, electrical plug and glue fitting)
- rebuild and exchange program with the unique claim of highest quality and best reliability

#### Technical data

operating voltage	230 or 120 VAC
frequency	50/60 Hz
sensor	FeCuNi or PT100 or Ni120 or NTC
heating power	starting at 320 watts
electrical connector	due to temperature sensor
temperature range	20-200 °C
cycle speed	max. 5.000 cycles/min.
glue inlet	BSPP 1/4 with different possible fittings such as UNF 9/16 or UNF 1/2 or UNF 3/4 or M16x1,5
glue pressure	up to 10 mPa (100 bars)
air connection	BSPP 1/8 or BSPP 1/4
air pressure	600 kPa (6 bar)
dimension A	min. 30 mm
dimension B	max. about 1.100 mm



cordset for all brands

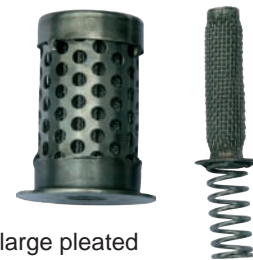

large pleated glue filter

small bayonet filter

#### All our products:

- hotmelt systems
- heated hoses
- applicator heads
- pattern controller
- coating machines
- print heads for hotmelt
- spare parts for all brands

#### We have ready solutions and develop individually for the:

- hygiene industry
- converting industry
- packaging industry
- filter industry
- wood working industry
- automotive industry

#### Your benefits @ APRO:

- we implement your needs
- we have long lasting professional competence (since 1992)
- we are fast and flexible
- we offer unlimited service availability and provide best quality products
- you will be our focus of attention

**APRO® Technologie GmbH**  
Im Huelsenfeld 19  
40721 Hilden  
Germany

Phone +49-(0)2103 - 39872-0  
Fax +49-(0)2103 - 39872-11  
www.apro-systems.com  
E-Mail info@apro-systems.com

The content is copyrighted.  
Reprinting is prohibited.  
HMC45NV-E APRO GmbH © 2011