

Slot applicator HMC62

for continuous coatings with coat weights above 20 g/m²

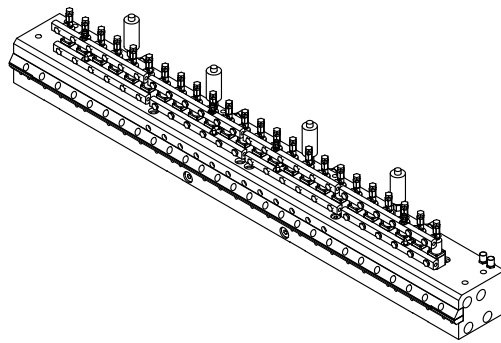
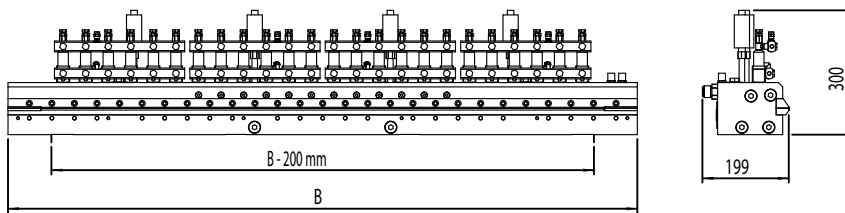

APRO slot applicator series HMC62 were designed for continuous applications with high coat weights.

The approved control modules HMC51 combined with an optimised slot nozzle design and a highly accurate cross section glue distribution allow coat weights from 20 to 200 g/sqm. These coat weights are needed for manufacturing self adhesive material like tapes or films. This applicator is also used to manufacture textile composites and wooden products.

Our slot nozzle is easily changeable. Size changes are done quickly without disassembling the whole applicator.

Depending on our customer requirements we are designing this type of applicator with more than one glue pressure zone. In this case multiple gear pumps supply the adhesive to the applicator. This guarantees most constant coat weights across and down the roll.

If necessary we provide glue pressure sensors mounted into the applicator. These sensors are monitoring the production and ensure constant coating results.

Our standard features:

- glue filter as standard
- reliable control module easy to be repaired
- high quality heater cartridges and temperature sensors
- ready-to go available for major brands of adhesive supply units (with correct sensor, electrical plug and glue fitting)

Technical data

operating voltage	230 or 120 VAC
frequency	50/60 Hz
sensor	FeCuNi or PT100 or Ni120 or NTC
heating power	approx. 300 watts/100 mm
electrical connector	due to temperature sensor
temperature range	20-200 °C
glue inlet	BSPP 3/8 or 1/2 with fittings UNF 3/4 or UNF 7/8 or M22x1,5
glue pressure	up to 10 mPa (100 bars)
air connection	BSPP 1/8 or BSPP 1/4
air pressure	600 kPa (6 bar)
coating width	300 - 1.500 mm
dimension B	500 - 1.700 mm

All our products:

- hotmelt systems
- heated hoses
- applicator heads
- pattern controller
- coating machines
- print heads for hotmelt
- spare parts for all brands

We have ready solutions and develop individually for the:

- hygiene industry
- converting industry
- packaging industry
- filter industry
- wood working industry
- automotive industry

Your benefits @ APRO:

- we implement your needs
- we have many years of professional competence (since 1992)
- we are fast and flexible
- we offer unlimited service availability and provide best quality products
- you will be our focus of attention

APRO® Technologie GmbH
Im Huelsenfeld 19
40721 Hilden
Germany

Phone +49-(0)2103 - 39872-0
Fax +49-(0)2103 - 39872-11
www.apro-systems.com
E-Mail info@apro-systems.com

The content is copyrighted.
Reprinting is prohibited.
HMC62-E APRO GmbH © 2011