

curtaincoat applicator

for continuous, non-contact coatings above 1 g/m²

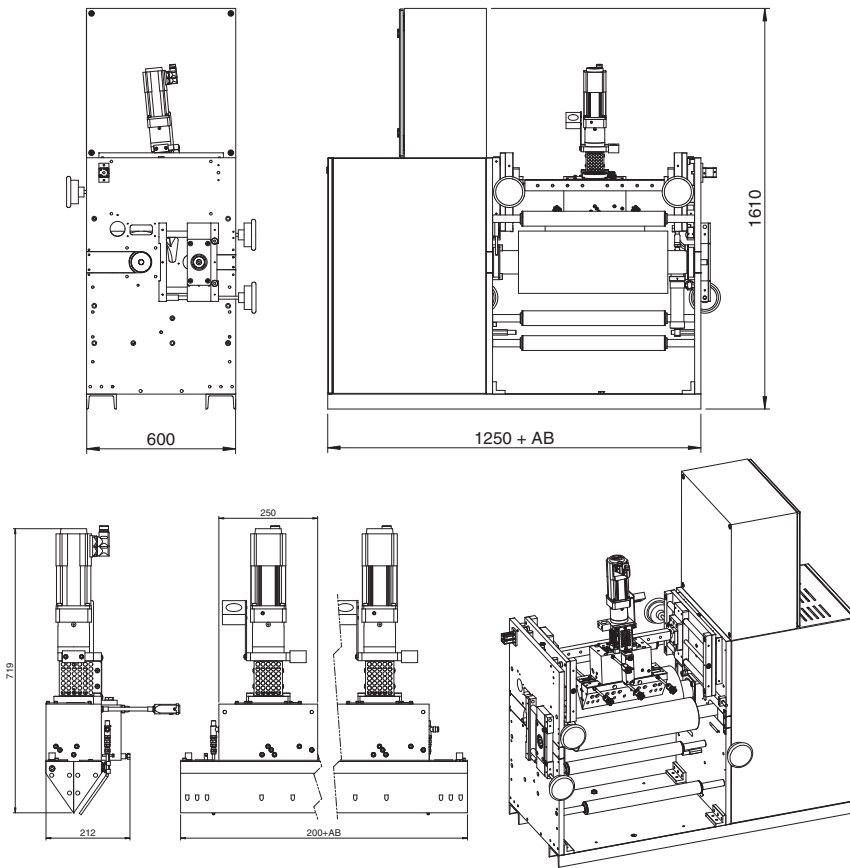

APRO coating applicators series CC have been developed for precise continuous coating applications. This contactless application method gives lots of new benefits to the coating industry. The applicator is almost wearless, because no adhesive valves are being used. Multiple output gear pumps on this applicator guarantee the highly precise coating thickness (coat weight). The gear pumps are mounted directly to the applicator. We use an up-to-date plc control to allow total control and easy use.

A series CC applicator is usually used on a coating unit with driven, chilled coating rollers and a nip-station. The nip is mainly responsible for the bond between the adhesive film and the coating substrate. The coating unit is an essential part of the CC application method being supplied if needed.

Technical data applicator

operating voltage	230 or 120 VAC
frequency	50/60 Hz
sensor	FeCuNi or PT100 or Ni120 or NTC
heating power	approx. 1.000 watts/200 mm
electrical connector	due to temperature sensor
temperature range	20-200 °C
glue inlet	BSPP 1/4 with different possible fittings such as UNF 9/16 or UNF 1/2 or UNF 3/4 or M16x1,5
glue pressure	up to 10 mPa (100 bars)
application width	250 to 2.000 mm
coating weight	1 to 250 g/m ²
section size per pump	250 mm (8x 31,25 mm)
adhesive viscosity	up to 150.000 MPas

Our standard features:

- glue filter as standard
- reliable gear pumps in various different sizes
- process control and user comfort using plc and touch panels
- high quality heater cartridges and temperature sensors
- ready-to go available for major brands adhesive supply units (with correct sensor, electrical plug and glue fitting)
- rebuild and exchange program with the unique claim of highest quality and best reliability

All our products:

- hotmelt systems
- heated hoses
- applicator heads
- pattern controller
- coating machines
- print heads for hotmelt
- spare parts for all brands

We have ready solutions and develop individually for the:

- hygiene industry
- converting industry
- packaging industry
- filter industry
- wood working industry
- automotive industry

Your benefits @ APRO:

- we implement your needs
- we have long lasting professional competence (since 1992)
- we are fast and flexible
- we offer unlimited service availability and provide best quality products
- you will be our focus of attention

APRO® Technologie GmbH
 Im Huelsenfeld 19
 40721 Hilden
 Germany

Phone +49-(0)2103 - 39872-0
 Fax +49-(0)2103 - 39872-11
 www.apro-systems.com
 E-Mail info@apro-systems.com

The content is copyrighted.
 Reprinting is prohibited.
 CC-E APRO GmbH © 2022